

more information at:



maximum-power laser scanning

The scan systems of the powerSCAN series enable positioning multiple kilowatts of laser power onto a workpiece in just a few milliseconds. In combination with a varioSCAN, the laser beam can be dynamically focused within working volumes, thus allowing non-flat workpieces to be processed.

Apertures from 33 mm up to 70 mm allow small spot sizes and therefore high power densities even with large working distances. The XY mirrors and the varioSCAN's optics are air cooled, while the scanners, electronics and varioSCAN are water cooled. This ensures reliable operation with excellent long-term stability – even under challenging environmental conditions and with high laser powers.

Each axis of the powerSCAN 50, 50i, 70 and 70i is individually implemented as a sealed submodule – a calibrated and tuned unit

containing a galvanometer scanner with a mirror and the scanner's drive electronics. Thus, rapid replacement of individual axes is ensured. Located in a separate sealed base module, the modularly-designed main electronics provide functions such as a digital interface and a power management system with comprehensive monitoring functions.

The powerSCAN i-series of scan systems employs the same iDRIVE® electronic concept used in the success-proven intelliSCAN®. This brings improved dynamics and advanced querying possibilities. The series includes both the powerSCAN 50i and powerSCAN 70i.

Typical applications:

- Laser processing of materials
- Rapid manufacturing
- 3D applications
- Processing-on-the-fly

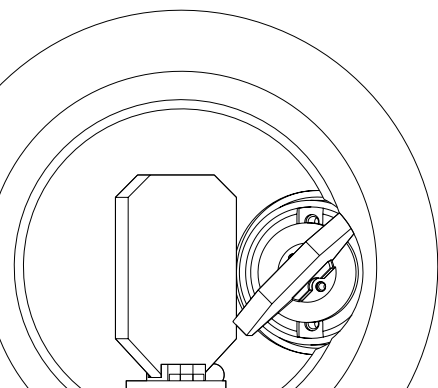

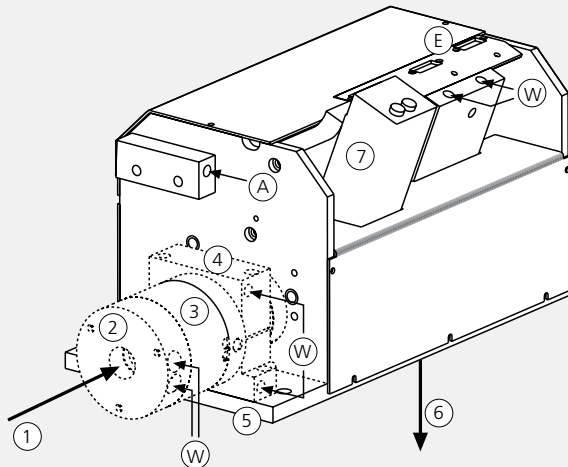

Legend

- 1 Beam in
- 2 Entrance aperture (water-cooled)
- 3 varioSCAN 40
- 4 Clamping block (water-cooled)
- 5 Base plate
- 6 Beam out
- 7 Galvanometer scanner
- E Electrical connectors
- A Connector for cooling air
- W Connectors for cooling water

all dimensions in mm

Beam entrance side

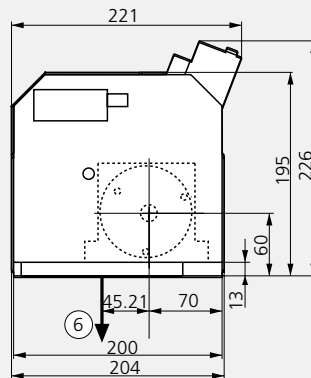

Beam exit side

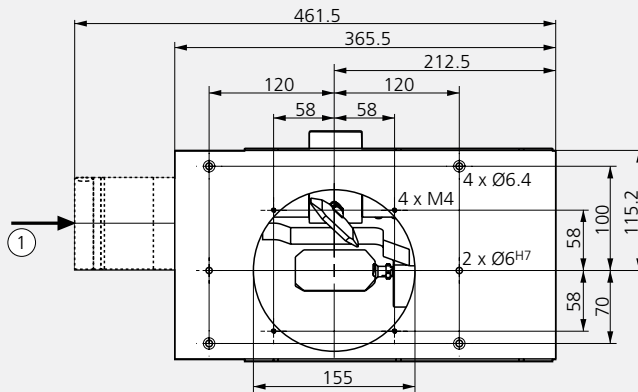

Dimensions	powerSCAN 33
Aperture	33 mm
Beam displacement	45.21 mm

Optics

SCANLAB precisely optimizes and tunes all optical components to one another to ensure maximum focus quality and stable process parameters.

The powerSCAN can be equipped with a varioSCAN for dynamically focusing the laser beam.

Numerous optical configurations – specially developed for the varioSCAN and matched to the powerSCAN – are available for various wavelengths, laser powers and image fields or working volumes.

Customers can easily self-install these exchangeable varioSCAN optics sets to adapt the scan system for their applications.

Control

The powerSCAN systems can be controlled via a SCANLAB RTC® control board. This facilitates straight-forward implementation of applications – even complex ones.

The RTC® board automatically performs all required computations, such as micro-vectorization and image field correction, and synchronously controls the powerSCAN, varioSCAN and laser.

Processing-on-the-fly functionality is optionally available.

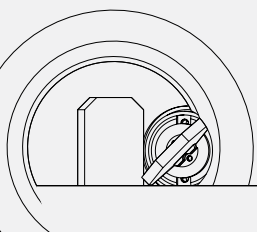

powerSCAN 50 and powerSCAN 70 scan systems may be equipped with interfaces for electrical or optical data transfer. powerSCAN 50i and powerSCAN 70i systems are controlled via the SL2-100 interface.

Options

- powerSCAN systems can be equipped with an additional reference sensor system for automatic self-calibration for applications requiring extremely high long-term stability
- powerSCAN systems can be equipped with sensors for monitoring the cooling air (standard at powerSCAN 50, 50i, 70 and 70i)
- Beryllium mirrors are optionally available for maximized dynamic performance (powerSCAN 33 and 50)
- powerSCAN 50i and 70i afford all advantages of the iDRIVE® technology: high flexibility, high dynamic and real-time querying of the actual position and other status data

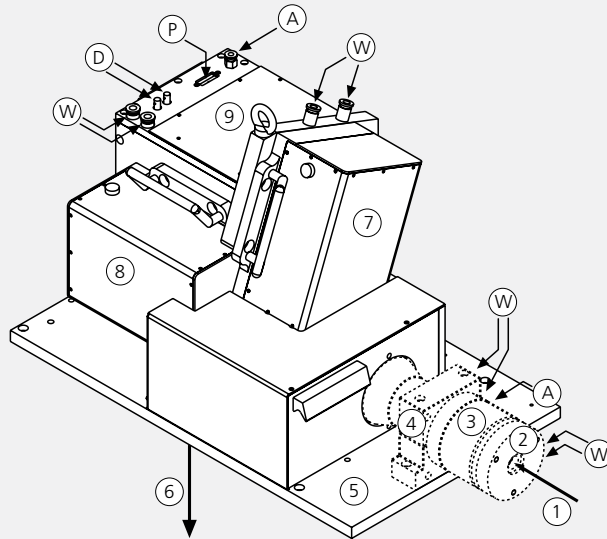

Legend

- 1 Beam in
- 2 Entrance aperture (water-cooled)
- 3 varioSCAN 60
- 4 Clamping block (water-cooled)
- 5 Base plate
- 6 Beam out
- 7,8 Submodules
- 9 Base module with main electronics
- D Fiber connector for optical data transfer
- P Power supply connector
- A Connectors for cooling air
- W Connectors for cooling water

all dimensions in mm

Beam entrance side

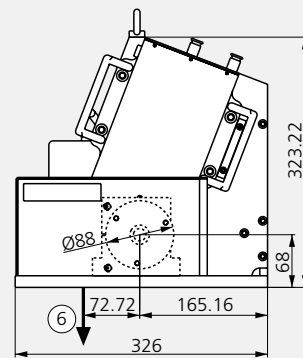

Beam exit side

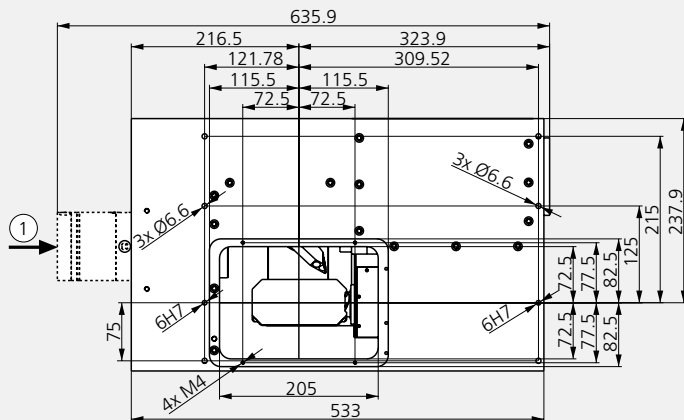

The powerSCAN 70 and 70i have a larger housing (L/W/H 566mm/360mm/342mm) compared to the pictured powerSCAN 50 and 50i, but have the same function unit.

Dimensions	powerSCAN 50/50i	powerSCAN 70/70i
Aperture	50 mm	70 mm
Beam displacement	72.72 mm	98.2 mm

Typical Optical Configurations

	powerSCAN 33 with varioSCAN 40			powerSCAN 50/50i with varioSCAN 60/varioSCAN _{de} 60i			
Wavelength	10.6 µm	10.6 µm	10.6 µm	10.6 µm	10.6 µm	10.6 µm	10.6 µm
Max. laser power cw	2000 W	2000 W	2000 W	2000 W	2000 W	2000 W	2000 W
Max. laser power for 50% duty cycle	4000 W	4000 W	4000 W	4000 W	4000 W	4000 W	4000 W
Image field size	(170 x 170)mm ²	(500 x 500)mm ²	(1.5 x 1.5)m ²	(400 x 400)mm ²	(600 x 600)mm ²	(800 x 800)mm ²	(1.0 x 1.0)m ²
Typical processing speed	0.8 m/s	2.0 m/s	6.0 m/s	1.3 m/s	2.0 m/s	2.7 m/s	3.2 m/s
Focus range in z direction	±4 mm	±35 mm	±75 mm	±10 mm	±40 mm	±50 mm	±100 mm
Focus diameter (1/e²)	210 µm (M ² =1)	450 µm (M ² =1)	1.3 mm (M ² =1)	250 µm (M ² =1)	375 µm (M ² =1)	500 µm (M ² =1)	600 µm (M ² =1)
Beam expansion factor	2.5	2.4	2.2	3.8	3.6	3.5	3.4
Focal length	(414 ± 15)mm	(850 ± 75)mm	(2300 ± 500)mm	(750 ± 50) mm	(1050 ± 90) mm	(1350 ± 150) mm	(1650 ± 250) mm

	powerSCAN 70/70i with varioSCAN 80/varioSCAN _{de} 80i		
Wavelength	10.6 µm	10.6 µm	10.6 µm
Max. laser power cw	2000 W	2000 W	2000 W
Max. laser power for 50% duty cycle	4000 W	4000 W	4000 W
Image field size	(440 x 440)mm ²	(1.0 x 1.0)m ²	(1.6 x 1.6)m ²
Typical processing speed	0.9 m/s	2.0 m/s	3.2 m/s
Focus range in z direction	±10 mm	±75 mm	±200 mm
Focus diameter (1/e²)	220 µm (M ² =1)	450 µm (M ² =1)	650 µm (M ² =1)
Beam expansion factor	4.9	4.5	4.6
Focal length	(860 ± 45) mm	(1680 ± 200)mm	(2440 ± 400)mm

Type-Dependent Specifications

(all angles are in optical degrees)

	powerSCAN33	powerSCAN50/50i	powerSCAN70/70i
Aperture	33 mm	50 mm	70 mm
Beam displacement	45.21 mm	72.72 mm	98.2 mm
Step response time (settling to 1/1000 of full scale)			
1% of full scale	1.3 ms	1.5 ms / 2.0 ms ^(*)	2.8 ms / 3.5 ms ^(*)
10% of full scale	4.5 ms		
Typical processing speed	3 rad/s	2.5 rad/s	1.5 rad/s
Typical positioning speed	18 rad/s	15 rad/s / 25 rad/s ^(*)	12 rad/s / 15 rad/s ^(*)
Dynamic performance			
Tracking error	0.75 ms	0.9 ms	1.6 ms
Power requirements	±(15+1.5) V DC, max. 4.5 A each	±(24+1.5) V DC, max. 10 A each (20 A peak current)	±(24+1.5) V DC, max. 10 A each (20 A peak current)
Weight (with varioSCAN)	12 kg	33 kg	35 kg
Typical air requirements	clean, filtered air > 1.5 bar	clean, filtered air 1.5 bar to 2.0 bar	clean, filtered air 1.5 bar to 2.0 bar

(*) the higher value applies to the powerSCAN i

Common Specifications

(all angles are in optical degrees)

Dynamic performance

Repeatability	< 22 µrad
Long-term drift over 8 hours (after warm-up)	< 0.6 mrad

Optical performance

Typical scan angle	±0.35 rad
Gain error	< 5 mrad
Zero offset	< 5 mrad
Skew	< 1.5 mrad
Nonlinearity	< 2.1 mrad

Input signals

Analog version (not powerSCAN i)	alternatively: ±4.8 V; ±9.6 V; ±4.8 mA; ±9.6 mA
-------------------------------------	---

Digital version	
• powerSCAN	XY2-100 Standard, optionally optical data transfer
• powerSCAN i	SL2-100

Output signals

	3 status signals per axis
Analog version (not powerSCAN i)	TTL level

Digital version	
• powerSCAN	XY2-100 Standard, optionally optical data transfer
• powerSCAN i	SL2-100

Operating temperature 25 °C ± 10 °C

Typical water requirements max. 4.5 bar